

**AFAAN GABRA  
BUGI BARATA  
MIN TOK**

**1**

© KENYA INSTITUTE OF CURRICULUM DEVELOPMENT

Waani malaa chuf ta wor bugi tan baase. Isi kuta bugi tana irra hibamne, ak chufa fu fakena ak elektroniki, mekaaniki, fotokopin, rekodun ka qorsuman dhuratu hibesisin wor bugi tan baase.

© Kenya Institute of Curriculum Development

ISBN NO: 978-9914-43-273-2

Baresitin kara

Kenya Institute of Curriculum Development

P. O. Box 30231-00100

NAIROBI-KENYA

Telephone: (020) 3749900-9, 3747994

Fax: 254 (020) 3639130

E-mail: [info@kicd.ac.ke](mailto:info@kicd.ac.ke).

## WAN BUGI KEJIR

KUTA 1: WORR.....	1
KUTA 2: SKUL KIY .....	9
KUTA 3: ADHAB DHASSA .....	15
KUTA 4: FAYYUMA .....	19
KUTA 5: BARA WOGA .....	28



## KUTA 1: WORR

### A. Ch'aqasi jed'

#### Huji 1

Bicha tan laal. Maan agart?

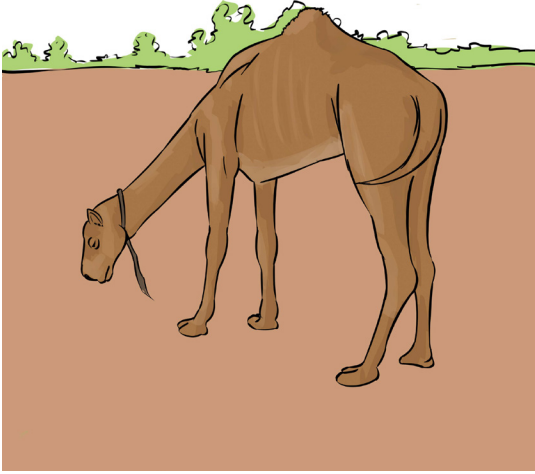

gaal

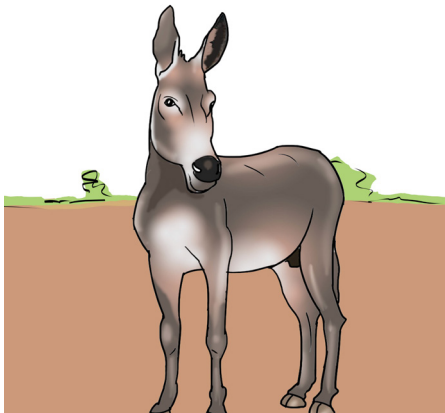

harre

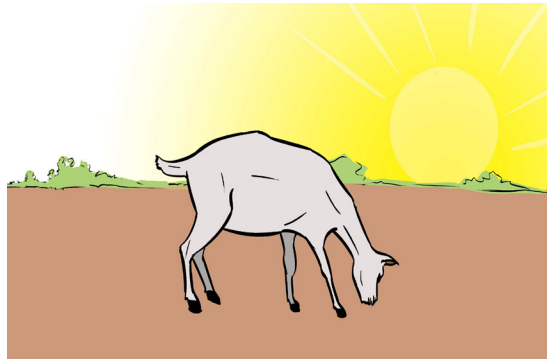

reti



gorfa

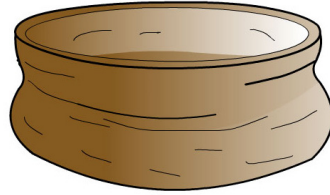

d'ammeela



chich'o

## Huji 2

Barsisan dhuridhuri isani d'aa . Chaqasa dhuridhuri suni.





### Huji 3

Baratot wolinsomtān ch'aqas. Wan wori jed sun toch.

- Man itsomtān har.
- Deski kanke rig.
- Balbal ch'uf.
- Qench d'ed'era ch'irad.

## A. Ka hasofnu

### Huji 1

Sirb barsisa sii sirb chaqas .Gul sirb.

### Huji 2

Bicha tan laali ak nagay wolfud'an jed.

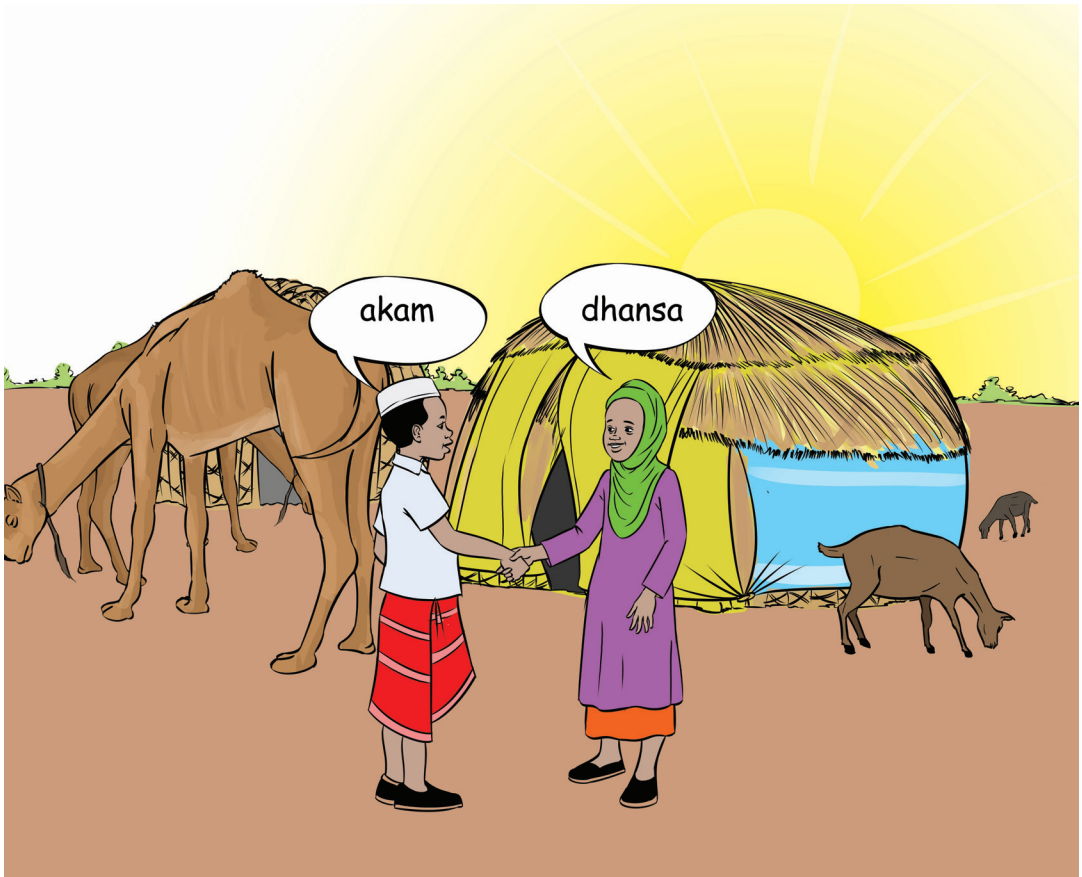





Jech kan jed'.	
1. Akam	2. Nagayat
3. Bultin bad'ad'a	4. Oliin bad'ad'a
5. Galchumi bad'ad'a	6. Nagayan bul

**Huji 3:**

Tap tapad'a. Barsisan ak isan tapatan isan garsis.

**CH. Ka soomnu**

**Huji 1:**

Bicha tan laali wan agart jed.



moqa



kokombe

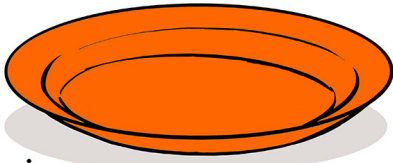

Sani

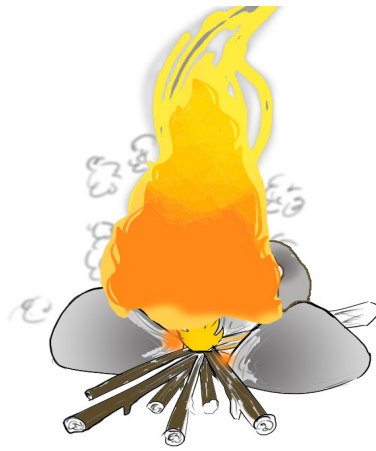

ibid



kature

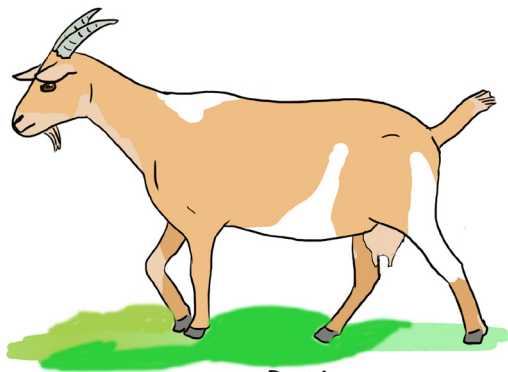

Reti

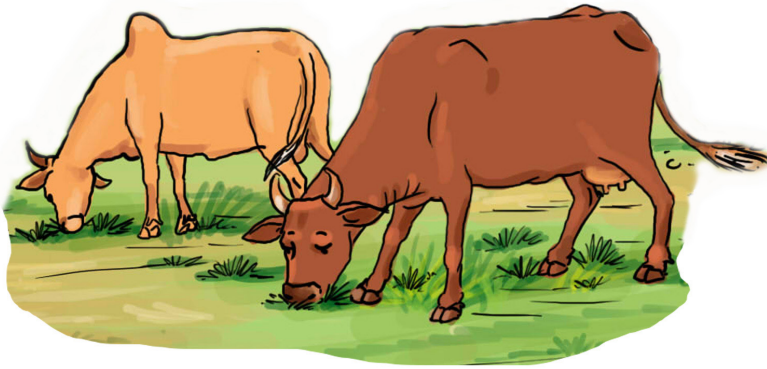

loon

## Huji 2

Kadi barsisan isan garsis lala. Wan irat agart soom.

## Huji 3

Huji dharama

Qarqas wor kesanitin,horif wan d'ibi gara worra kesat agart hiim.

## D. Ka qorru

Huji 1:

Bugi tante laal. Qiles kesat wan lalt qor.

a e i o u

Huji 2

Wael kanketin wolin wan qiles kesat qortan doqen qora.

Huji 3

Wan qiles kesat qortan bugi kesat qorad'a.

## KUTA 2: SKUL KIY

### A. Ch'aqasi jed'

#### Huji 1

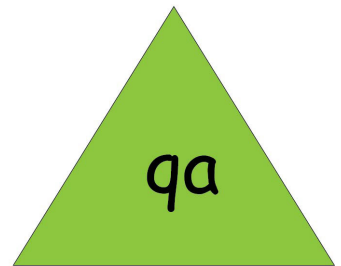
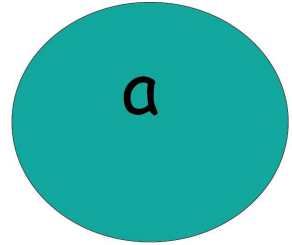
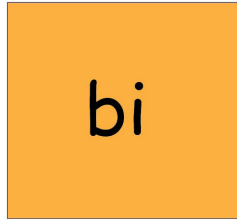
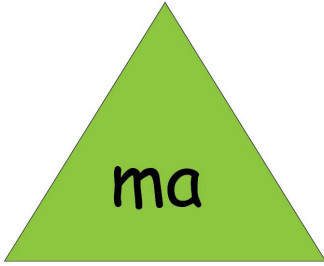

- a) Bicha tan laal.
- b) Man agart?
- c) Wael kanketin him.

#### Huji 2

Lamlaman,

- a) Wan bicha sun kejira sooma.
- b) Nam si birtau iss som ch'aqas.

## Huji 3

Lamlaman,

- a) Bicha wolfakat wankes jiran walt dhara.
- b) Wan walt dhartan sun wolin soma.
- c) Wael kanke ak inni som ch'aqas.

## Huji 4

- a) Wan barsisan jed' ch'aqasa.
- b) Jech sun fula fulat gargar bas.
- c) Akhekha, abo = a bo  
Ako = a ko  
Adha = a dha
- d) Fula kamu som.
- e) Wael kanke ak inni fula kamu som ch'aqas.

## B.Ka Hasofnu

### Huji 1

Wael ketit him,

- a) Wan barsisan toch sin jed'.
- b) Wan barsisan naman jede,maf gul dheman?

## Huji 2

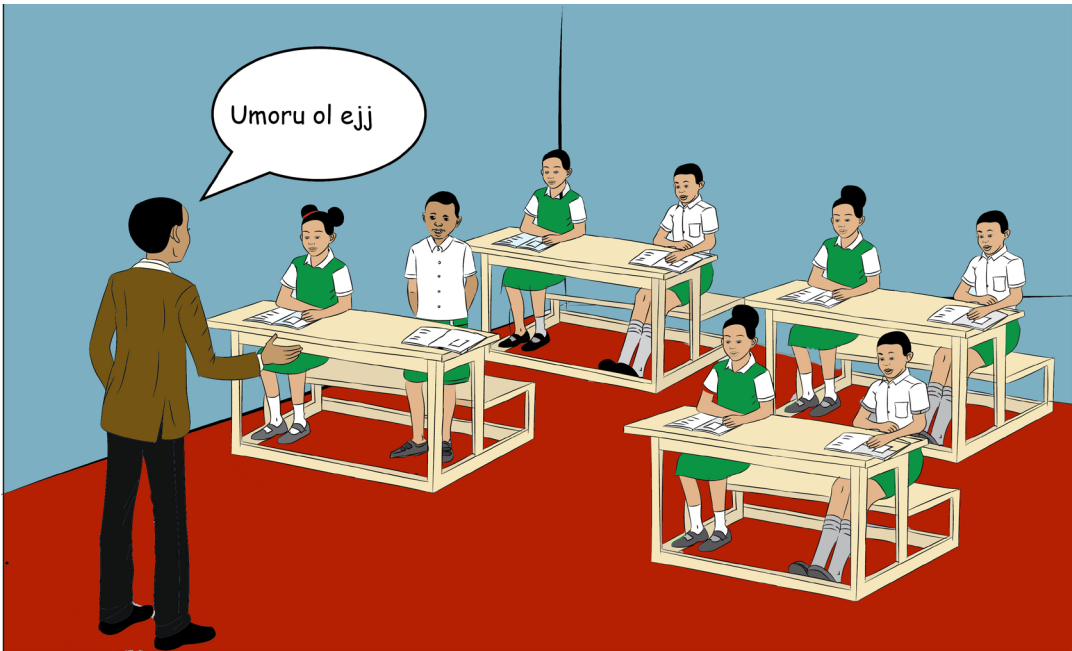

Bicha tan lal.

- Barsisan Umuron man tai jeden?
- Umuron man tahu mal?
- Dhubbi barsisa, Umuron maf dagau mal?

## Huji 3

- Wan barsisan jed'e ch'aqas.
- Wan barsisan toch sinj'ede toch.

# CH.Ka soomnu

## Huji 1

Tutani,

a) Bicha tan laala.



mbira



bilbil

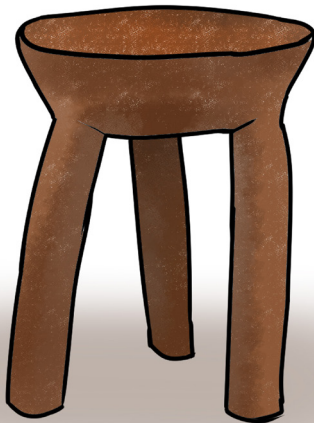

barchuma



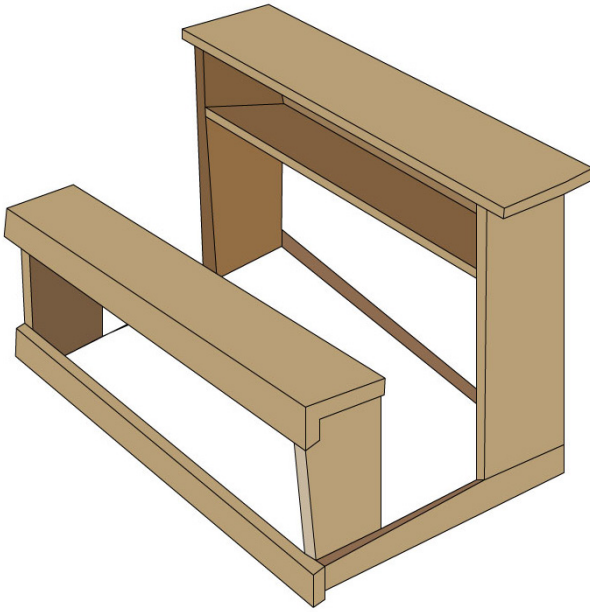

deski

b) Qonqo qara jed'i.

## Huji 2

Lamlaman,

- a) Wan skul kesat argan maqesa.
- b) Jech sun soma.
- c) Bugi tesan qesat jech sun qorada.

## Huji 3

Jech qoratan sun wor kesani soma.

## D. Ka qorru

### Huji 1

Jech kan qiles kesat qorra.

- a) Mesa
- b) Barch'uma
- c) Bandera

### Huji 2

Jech kan hanqo gutt.

- a) Ba-bal
- b) B-gi
- c) Kar-
- d) Ijoll-

### Huji 3

- a) Chaq'as wan barsisan som.
- b) Wan barsisan som sun qorad.

# KUTA 3: ADHAB DHASSA

## A. Ch'aqasi jed'

### Huji 1

- a) Dhuridhuri barsisan si som ch'aqas.
- b) Dhuridhurin sun man irra dubat?
- c) Maqa wor dhuridhuri sun kee jiru him.
- d) Jech adhab dhassa garsisu dhuridhuri sun kesa him.

### Huji 2

Tutani,

- a) Dhuridhuri barsisan isani d'au ch'aqasa.
- b) Dhuridhuri sun amalle d'ai.

## B. Ka Hasofnu

### Huji 1

Sirb

- a) Sirb kan d'ad'a.

#### **Adhab dhassa**

Kesumma diada

Nu nagay isan funa

Nagayat jenna yo kesuman galte

Galatom jena yo wa nukenan

Ralidhi naqabad jena yo an sidabele

- b) Sirbi kun maan irra dhubat?
- c) Wael kanket him.

## Huji 2

---

Tutani tapad'a,

- a) Sub kesa jech qoran tok fud'ad'.
- b) Jech fut sun qorba d'ibi agarsis.
- c) Jech fut suni dhubi irra mid'as.

## Huji 3

---

Lamlaman wan skul kesani irra hasaa. Jech adhab dhassa garsisu kesat dhubad'a.

# CH.Ka soomnu

## Huji 1

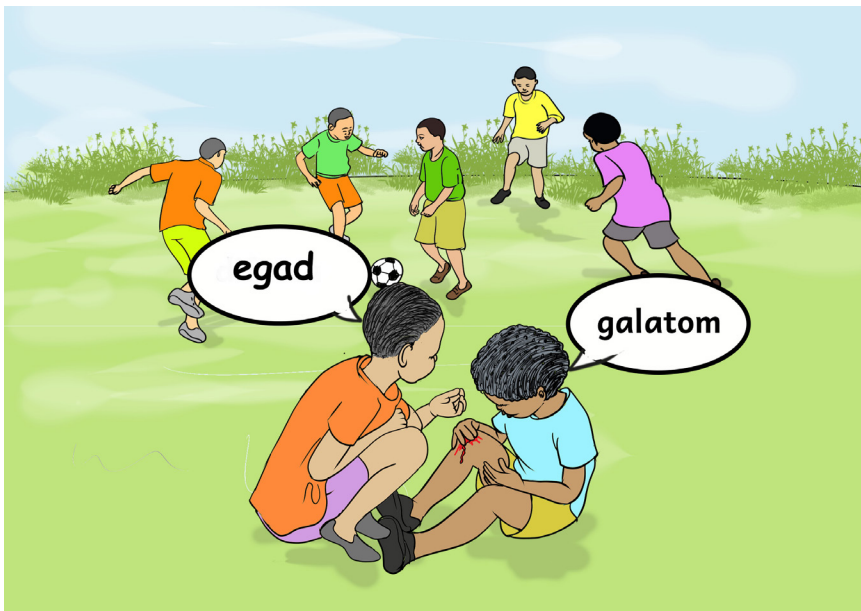
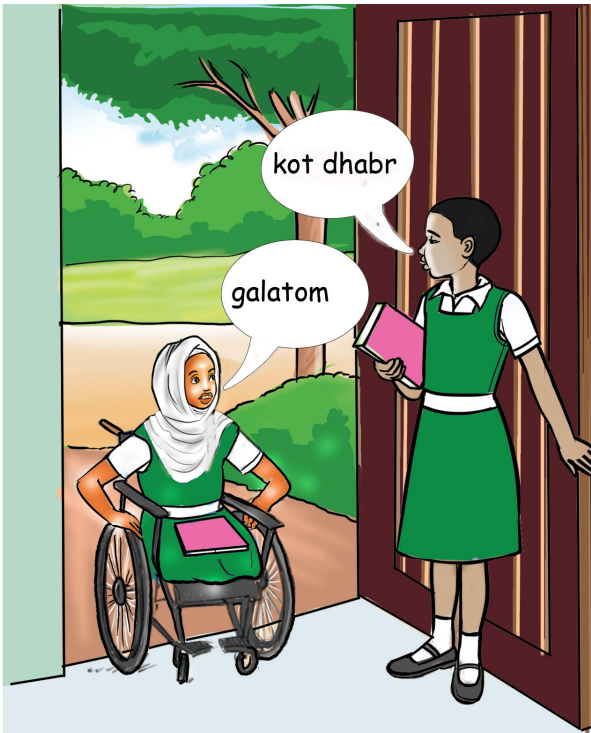

Lamlaman,

- a) Bicha tan laala.
- b) Man agartan?
- c) Jech bicha kecir sooma.

## Huji 2

- a) Sirb adhab dhassa d'ad'a.
- b) Barsisan kanke, ak at sirbit sigarsis.
- c) Jechi adhab dhassa garsisu sirb sun kesa filad'a.

## CH.Ka qorru

### Huji 1

- a) Jech barsisan soom ch'aqas.
- b) Jech sun bugi tante kessat qorad.

### Huji 2

Jech kan hanqo guut.

- a) \_\_\_\_\_ alat gath bao? (D'ifama, D'iad'i)
- b) \_\_\_\_\_ anin ya ture. (Anin akan jed', Ralidhi qabad')
- c) \_\_\_\_\_ ka kalamu nakenit. (Galatom, D'ifama)

### Huji 3

Dhubi tan qorad'a.

- a) Adha d'iad.
- b) Galatom ka d'iate.
- c) Ralithi qabad anan ya foqane.

## KUTA 4: FAYYUMA

### A. Ch'aqasi jed'

#### Huji 1

Sirb barsisan si sirb ch'aqas ammale gul sirb.

#### Huji 2

- a) Sirb sun wor kesani sirb.
- b) Worati, sirb sun jalowan tetin sirb.

#### Huji 3

1. Walalo barsisa si d'aatu ch'aqas.
2. Barsisa ketit him,
  - a) Dhiram ijolen man hojat?
  - b) Baratan skulat man hojat?

#### Huji 4

Bicha tan laal.Wan wori sun tahu jiru jed'.









## B. Ka Hasofnu

### Huji 1

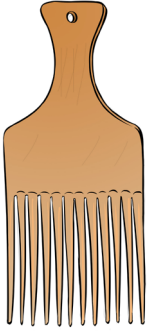
Barsisa kanke gul, jech kan jed.

	Fila
	Riga
	shabun



Hara

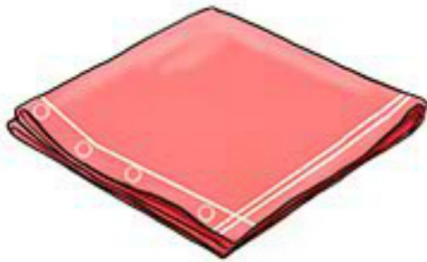

Bututu furo

## Huji 2

Bicha tan irra dhubad'.



## Huji 3

### a) Sirb kan sirb

Furro bututu isitin fudatan  
Qench d'ed'era hinch'iratan  
Guri guralle hinguratan  
Akanan fayyuma jabesan

Nu ijollen min toko, chafu injibin  
Chafu chuf gurra boll isit jisin

Ufira chafu d'inne gamane sirbin

- a) Sirb kun man irra dhubat?
- b) Sirb kan guya tok ka jil skula sirba.

## CH.Ka soomnu

### Huji 1

Bicha tan laali, wan agart wael kanketit him.



## Huji 2

Walalo tan sooma.

### Qulqulum qencha

Qench'i t'uri qab dhansanin

Qench'i t'uri qab fayya nud'ow

Anin qench kiy qulqulich fed'

Yo ch'uufa qench ken ka t'uri d'owaru

a) Oddun tun man irra dhubat?

b) Qench'i t'uri qab maf hama?

## D.Ka qorru

### Huji 1

Mii Kan huji isani qor.

Mii	Mii kan huji isani ma
	

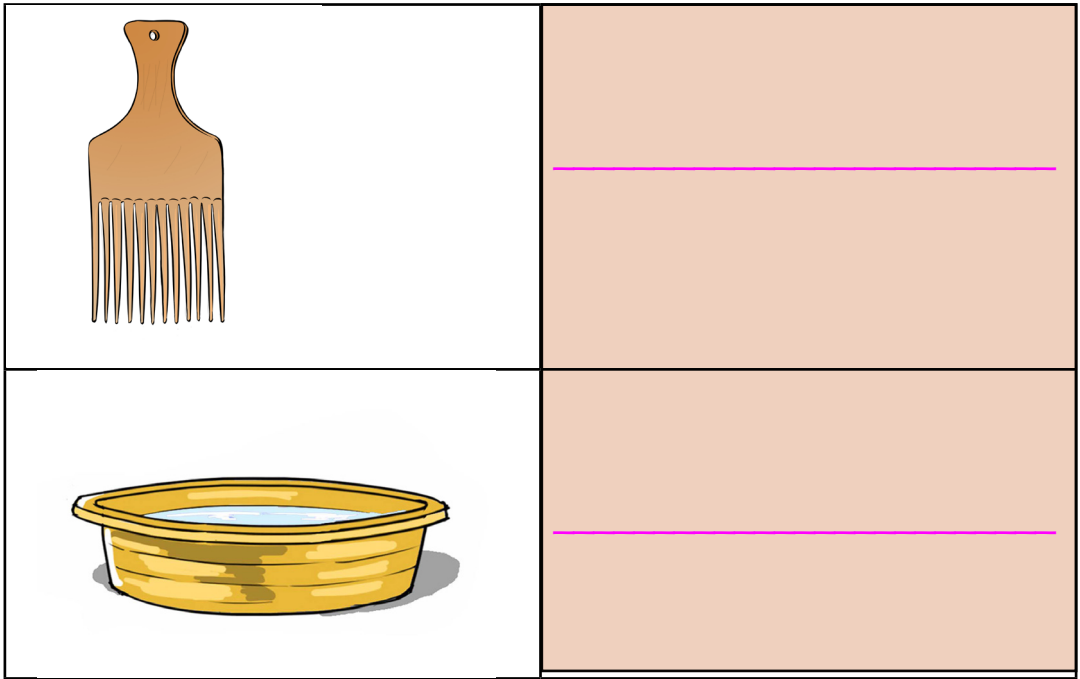

## Huji 2

Bicha tan barresi biff it toch.

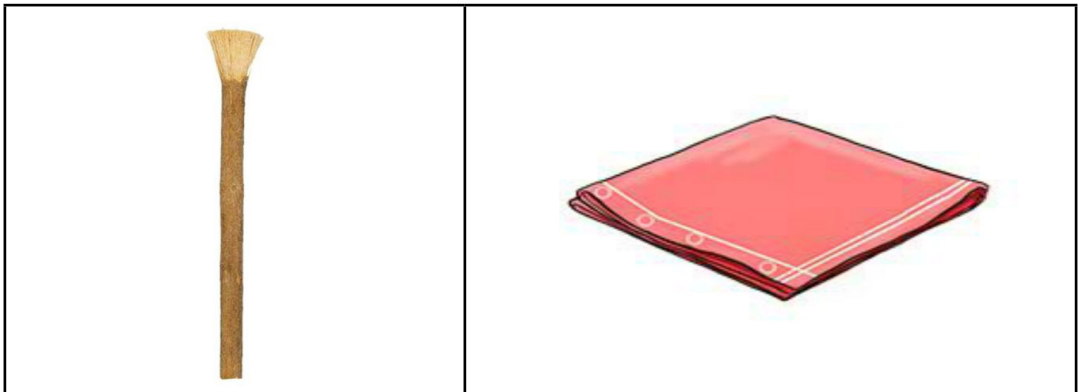

Wor kesani bicha baresit sun garsis.

## Huji 3

Jech kan hanqo gutt.

- a) r-ga
- b) fil-
- c) d-qad
- d) b-san

## Huji 4

Jech kan qor.

Kut	_____
haq	_____
d'iq	_____

# KUTA 5: BARA WOGA

## A. Ch'aqasi jed'

### Huji 1

Barsisa kanke gul jed.



Am saa tok.

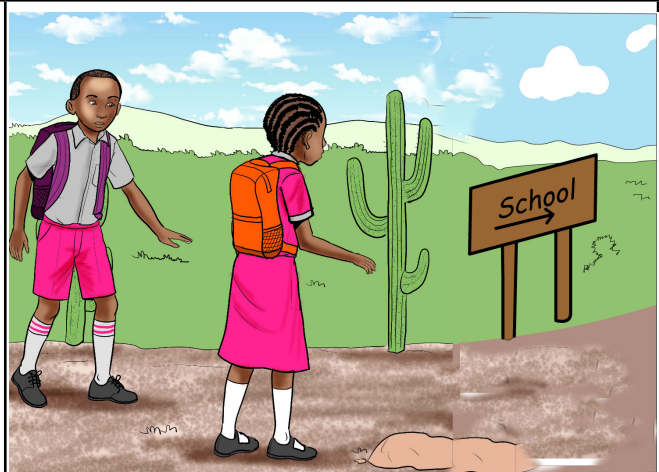

Gise skul dheman



Am saa torb.



Gise golol गया.



## Huji 2

a) Barsisa kanke gul sirb.

Am saa afur

Gise tapa

Am sa jaa

Gise golola

Am saa lam

Gise iriba

b) Sirb kan worr kesani sirb.

## B.Ka Hasofnu

### Huji 1

**Walalo kan jed'a.**

Adhof Ibraen Ahad d'alat

Mamof midina Alsinin d'alat

Talasof isaqon Talasa d'alat

Alif Arben Arbaa d'alat

Umorof Kamen Khamis d'alat

Gumatof Adanon Gumat d'alat

Sabdiof Abudhon Sabdi d'alat

a) Wael kanket him maqa ayan torbani.

## Huji 2



- a) Man bicha tan kesat agart?
- b) Bar kan benni man ojat?

## CH.Ka soomnu

### Huji 1

Jech tok sub kesa fud'i soom.

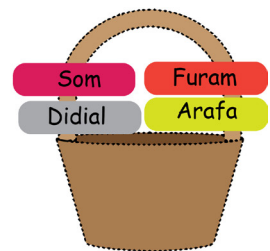
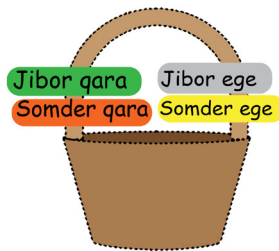

### Huji 2

Jech kan som ammale marsi dhebis.

1. Guya kam skul irra olan?
2. Gise tam gaal galchan?
3. Aftoon hori bar kam jirt?
4. Bari horin quf kam?

### Huji 3

Dhuridhuri soman.

- a) Dhuridhuri tan som.

Dhuridhuri jedan,dhuri goroo jedan,gol ibidha jed'an, reti qench bora jedan.

Dhuri yo rooba ,ayan sabdhitifi Ahadha, Adano ree ware galch.

Yo bona ree oba d'a .Adanon woragu galgal ree giset galch.  
Jenaan aban gamadhe ree kenef.

b) Gafi tan marsi dhebis.

i) Dhuridhuri tun man irra dhubat?

ii) Adano ayan kam ree tis?

iii) Adanon barr kam ree oba d'a?

## D. Ka qorru

### Huji 1

Hanqo guut maqa tumuu kes jirun.

Alsinin      Halkan      kud'anilam      dhiram

1. Nu yom lafa kakan?\_\_\_\_\_.

2. Ganni ji agam qab?\_\_\_\_\_.

3. \_\_\_\_\_ guya qara ka torbani.

4. \_\_\_\_\_gise rafan.

### Huji 2

Jech kan qorad'i ammale wor kesani som.

a) Guya rooba ree ware galt.

b) Dhiram kane skul yaan.

c) Kamen guyate sagale d'abdh.





REPUBLIC OF KENYA



**KENYA INSTITUTE OF CURRICULUM DEVELOPMENT**

Desai Road, Off Thika Rd.,

P.O. Box 30231 - 00100 Nairobi, Kenya.

Telephone : +254 (020) 374 9900 - 9, 374 8204, 374 7994

Fax : +254 (020) 363 9130.

Email : [info@kicd.ac.ke](mailto:info@kicd.ac.ke), Website : [www.kicd.ac.ke](http://www.kicd.ac.ke)